



Plungerlift

PetroTech

Wellhead Controller



Operating Manual

Table of Contents

Getting Started.....	Page 1
Operating Features.....	Page 2
Safety Constraints.....	Page 11
Maintenance Checklist.....	Page 12
Troubleshooting/FAQ's.....	Page 12
Rules of Thumb.....	Page 13
Multi Products Company – Diverse Line of Products.....	Page 14
Limited Warranty.....	Page 15
Registration.....	Back Cover

Getting Started

1. **BECOME FAMILIAR** – Prior to installing the controller on the well, it is suggested the user experiment with selecting settings to become familiar with using the Petro-Tech controller.
2. **VERIFY** – Make sure all PSI lines are properly connected.
3. **POWER UP** – Open cabinet door and flip the switch on the reverse side of the faceplate to the UP position. Display briefly shows the serial number and release version of the Petro-Tech unit, then displays [Current Status]. Initial status: Manual mode, valve(s) closed, all limits set to 0 (zero).
4. **SET LIMITS** – At minimum, the user must establish settings for opening and closing the well. Valve is set to open using [Hi Casing] and/or [Plunger Max] ([A Open Max] for a two valve system) and/or [Open Diff] and/or [Load Factor]. Valve is set to close using [Lo Casing] or [Line Safety] or [Close Diff].

Notes:

- The [Run] button starts the Automatic Cycle Mode from the beginning.
- The [Stop] button closes valves and puts the controller in Manual Mode.
- The central knob is used in two ways: Push to select an option, to move to a menu, or to execute a command. Turn to scroll options or to navigate through menus.
- The first option on every menu is [Back]. Selecting this moves to the previous menu. The last option on every menu is [Current Status]. Selecting this moves to the Current Status screen.
- The user is prompted to save or discard changes upon exiting a menu (via [Back] or [Current Status]). Changes to pressure settings do not take effect until they are saved. Changes to time settings are stored when they are saved, but do not take effect until the start of the next cycle.

- Shutting the cabinet door makes the display screen go to “sleep mode” to conserve battery usage. Shutting the cabinet door without saving changes to settings voids any changes that were entered. You must save settings to activate them.
- The top line of the [Current Status] screen provides descriptive details of the present state, such as an indication of fallback time.

Operating Features

MAIN MENU – Press the central knob to access the [Main Menu].

Battery Indicator – visually shows the current battery voltage. Fully charged is 3 bars. As the battery is used, voltage goes down to two bars, one bar, and then empty. When the battery indicator is blinking empty, the well will automatically shut in and the top line will display [Manual. LOW BATTERY]. Settings are stored in memory so if the battery fails, settings will not be lost. Batteries are rechargeable. Note that the controller automatically goes to Manual Mode in the event of a low battery.

Current Status – real-time status at a glance:

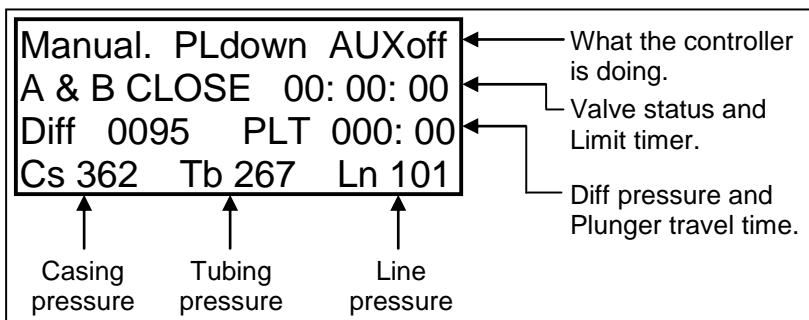

Mode = If controller is in Manual Mode, screen will display [Manual]. If controller is in

Automatic Mode, screen will display the current state of the controller.

PL up/down = If the plunger is down hole, screen will display [PLdown]. If the plunger has arrived, screen will display [PLup]. Note that this display only appears in Manual Mode.

AUX on/off = If an auxiliary switch is activated, screen displays [AUXon]. If an auxiliary switch is not activated, screen displays [AUXoff]. Note that this display only appears in Manual Mode.

A & B Status = Valve status (open or closed) and running time until the next valve event. B status is only indicated on a 2-valve system.

Diff = differential pressure between casing and tubing

PLT = plunger time, or the time it takes for the plunger to travel to the surface once the valve opens. Resets to zero on cycle start.

Cs = Real time casing pressure, in psi

Tb = Real time tubing pressure, in psi

Ln = Real time line pressure, in psi

Plunger History – displays logs of plunger activity:

View Log Summary = Displays number of plunger arrivals, number of total cycles, A valve open time, and A valve close time. Turn knob to view detailed logs. Press knob to return to [Plunger History] menu.

Erase Summary = Erases the log summary. When this option is selected, the user will be prompted to confirm the erasure of the summary.

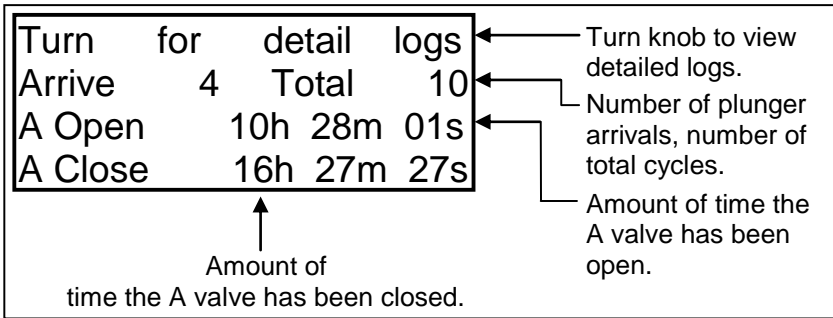

Turn for detail logs = Turn knob to view detailed cycle logs.

Arrive = Displays number of times plunger arrived.

Total = Displays total number of cycles.

A Open = Displays time A valve has been open.

A Close = Displays time A valve has been closed.

View All Logs = Shows all stored plunger history.

Turn knob to navigate through logs. Press knob to return to [Plunger History] menu.

View Missed Logs = Displays only the times when the plunger missed (searches back at least 100 plunger logs). Turn knob to navigate through logs. Press knob to return to [Plunger History] menu.

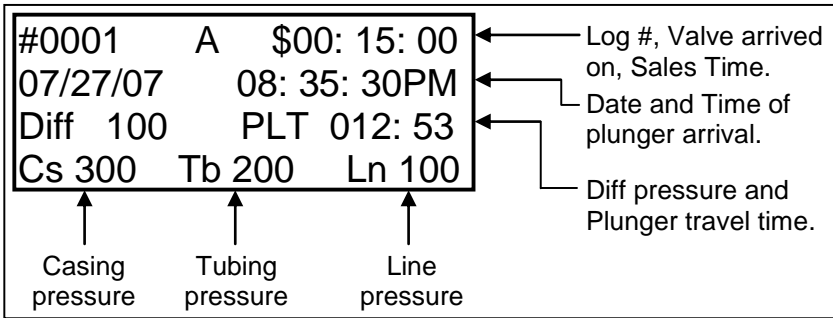

Log # = identifier, with most recent log numbered 0001.

A or B = Tells which valve the plunger arrived on.
 \$__:__:__ = Sales time, or the amount of time A valve is open and selling gas.

Date/Time = When the log was created.

Diff, PLT = Pressure differential at the time the plunger arrived or missed, and plunger travel time (or “missed” is indicated).

Cs, Tb, Ln = Pressures at the time the plunger arrived or missed.

Set Pressures – If you exit this menu via [Back] or [Current Status], you will be prompted to save or discard changes. Settings established here only take effect once they have been saved.

Load Factor = [Load Factor] is defined as casing pressure minus tubing pressure divided by casing pressure minus line pressure. (casing-tubing)/(casing-line). The well will open if the actual [Load Factor] is less than the value entered here.

Hi Casing = Minimum casing pressure needed to turn on the well. If the well is closed, it remains closed until the casing pressure reaches the level set here. Note that other

events, safety triggers, and settings can shut the well, overriding the casing settings.

Lo Casing = Lowest casing pressure that causes the valve to close. If the well is open, it will remain open until the casing pressure drops below the level set here. Note that other events, safety triggers, and settings can open the well, overriding the casing settings.

Open Diff = Differential between casing pressure and tubing pressure that triggers the well to open. If no [Hi Casing] level has been set, the well will open when the differential is lower than the [Open Diff]. If a [Hi Casing] level is set, both it and [Open Diff] must be met for the well to open.

Close Diff = Differential between casing pressure and tubing pressure that causes the well to close. If the differential is larger than the [Close Diff], the well will shut in. In a single valve system, this setting will not be considered until the plunger arrives.

Line Safety = Minimum differential between tubing pressure and line pressure. The tubing line differential must be higher than this setting to force gas into the line. The [Line Safety] setting limits how close the tubing pressure can get to the line pressure.

Hi Line = If line pressure is greater than this setting, the well shuts in. The well re-opens when line pressure drops below this setting.

Lo Line = If line pressure is less than this setting, the well shuts in. Typically, reaching [Lo Line] indicates a leak.

Hi Line Window = An advanced control option, the [Hi Line Window] is a band limit for the [Hi Line], to accommodate fluctuations right at

the [Hi Line] setting. It prevents the valve from repeatedly opening and closing. For example, if [Hi Line] = 150 and [Hi Line Window] = 10, the well shuts in when the line pressure reaches 150, but doesn't re-open until the pressure drops to 140.

Lo Line Window = An advanced control option, the [Lo Line Window] is a band limit for the [Lo Line], to accommodate fluctuations right at the Lo Line setting. For example, if [Lo Line] = 25 and [Lo Line Window] = 10, the well shuts in when the line pressure reaches 25, but doesn't open again until the line pressure is 35.

Shutin Pressure = When the plunger misses, the well will shut in and casing pressure must meet this setting to restart the cycle. [Shutin Pressure] must be greater than the [Hi Casing] setting.

Set Times – If you exit this menu via [Back] or [Current Status], you will be prompted to save or discard changes. Saved settings only take effect at the next cycle start.

Plunger Max = In a single valve system, the maximum time allowed for the plunger to arrive. If the plunger arrives before this time, other settings determine when the well closes and the timeout is no longer in effect. If the plunger does not arrive before the [Plunger Max] is reached, the valve shuts.

A Open Max = In a 2-valve system, the maximum time allowed for A to be open. If [A Open Max] expires before the plunger arrives, A is closed and B is opened (with delay, if specified – see below).

- A Close Time* = Amount of time that valve A will remain closed at the end of a cycle, whether plunger arrives or misses. Pressure settings override this setting.
- B Open Time (BOT)* = Available in a 2-valve system only, [BOT] is the maximum time allotted for the B valve to remain open.
- B Open Delay* = Available in a 2-valve system only, [B Open Delay] is an optional time delay between the A valve shutting and the B valve opening. [B Open Delay] allows time for the plunger to fall to the bottom of the tubing.
- B Purge* = In a 2-valve system, [B Purge] is the amount of time the B valve will stay open after the plunger arrives, in order to clear the B line of fluids.
- Fallback Time* = Amount of time to allow for the plunger to fall to the bottom of the tubing to get below the liquid before starting a new cycle.
- Shutin Time* = The amount of time the valve is shut after a missed plunger arrival, to build enough pressure to force the plunger up. Missed plunger arrival can be caused by insufficient pressure to lift the plunger up, or too much fluid to allow the plunger to return all the way up.
- Afterflow* = The amount of time valve A will remain open after the plunger arrives. [Lo Casing], [Hi Line], and [Lo Line] settings will override this setting. If a [Diff] setting is set, it will be considered when [Afterflow] time expires.

Valve A (open/closed) – Available in Manual Mode only, can be used to manually override established

settings. Timing of how long the valve is open is tracked on the Current Status screen (PLT Time).

Valve B (open/closed) – Available on a 2-valve system in Manual Mode only; can be used to manually override established settings. Note that Valve A and Valve B CANNOT be open at the same time. If Valve A is manually opened, Valve B cannot be manually opened.

Options

Aux = Optional input that opens or closes valves based on data from an external switch. For example, an auxiliary switch may be placed in the tank (tank topper) that prevents overflow by shutting in the valve when the liquid reaches the top of the tank. To utilize this option, input preferences on the following menu.

Label: User can determine label; that label appears on [Current Status] screen

A Valve: Indicate here what the valve does (On/Off) when the auxiliary switch activates.

B Valve: Indicate here what the valve does (On/Off) when the auxiliary switch activates (2-valve system only).

In the above example, the tank topper is the auxiliary switch, and the label would be “tank topper”. Because the user wants both valves to close when the tank is full, both valves would be set to [Off] using this menu. When the tank fills, the liquid activates the switch, which signals the valves to close. The program pauses where it was, and the valves close, waiting for the tank to be emptied. When the tank is

emptied, the topper switch re-sets, and the program resumes where it had paused. (If the A valve had been open prior to the program pause, it re-opens now.)

Mandatory Shutin = Closes the valve for an extended period of time when there are consecutive plunger misses. Note that the counter resets if the plunger arrives. Specify the mandatory shutin using the following menu.

Plunger Fail: Number of *consecutive* plunger misses that triggers mandatory shutin

Man. Shutin hours/min: Enter the duration of mandatory shutin, in hours and minutes

Set Date/Time = Specify the date and local time. This is used for time stamping logs (ex. [Plunger History] logs).

Version/Serial # = Select this option to view the controller version and serial number. View-only, this option cannot be changed by the user.

Well ID = Change the name of the well. The default [Well ID] is the controller serial number. USB Log is named using [Well ID]. The [Well ID] has a maximum of 8 characters.

USB Drive – When the USB drive is used to download or upload information, the screen displays the “percent done” to indicate data is being copied.

Download recent log = Download logs of recent activity (since the last download), from the controller to the USB drive.

Upload Settings = Upload new settings from the USB drive to the controller.

Download total log = Download all logged information, from the controller to the USB drive.

Multi Technician = Security function for Multi personnel use only.

Safety Constraints

EXTREME CAUTION! Carefully choke the well to **limit plunger speed** to safe levels (recommended optimum = 750-850 ft/min upon arrival). If there is little or no fluid on top of the plunger and there is sufficient pressure and volume, the plunger can burst through the steel lubricator and high into the air, causing serious injury or death.

EXCESSIVE PLUNGER SPEED IS DANGEROUS!

Multi Products Company, Inc. and its affiliates are not responsible for injury or death caused by careless or reckless operation of the controller. Use caution to choke the well to limit plunger speed. Contact a sales representative for available chokes.

Please observe these additional safety precautions:

- Even with the features of this controller, gas is present around the well and is highly flammable. **Never smoke near the well.** Basic well safety must be followed.
- Do not turn the power on/off or change the battery in an explosive atmosphere. Doing so creates a spark hazard that could ignite the gas present in the air.
- Prior to disconnecting the battery for removal, make sure the power switch is OFF.
- Use care when running a bypass valve (where there is no choke) to ensure sufficient fluid above the plunger to slow the plunger to within safe speeds.

- Note that the plunger clicks upon rising, once every 40 feet as it passes the tubing joints. Approximate plunger speed can be determined by timing between clicks.

Maintenance Checklist

Repeated plunger misses can indicate a worn plunger. Periodically check plunger diameter. The frequency of this check is based on plunger usage, well cycles, and well conditions. Contact your sales representative for guidelines for your plunger model.

The following checks should be conducted **weekly**:

- Verify the solar panel is clear of obstructions and facing the sun.
- Pull the solar panel plug and verify that the battery is sufficiently charged and holding charge.
- Visually and audibly verify the mechanical solenoid valve is working and free of debris.

Troubleshooting/FAQ's

Q: My transducer pressure is inaccurate...can I recalibrate?

A: No calibration is required. If pressure readings are inaccurate, the transducer needs to be replaced. Contact your sales representative.

Q: My battery indicator is blinking low...what do I do?

A: If the battery gets low at night, unplug the solar panel to verify the battery is holding charge. If not, replace the battery. If the battery indicator is blinking with the solar panel in place, verify the solar panel connections. If the solar panel is functioning and connections are established, the battery needs to be replaced.

Q: My Current Status screen shows PLUNGER ERROR... what does this mean?

A: The plunger arrival sensor is stuck. Check the inside of the lubricator for metal shavings, and clear them if necessary. If there are no shavings blocking the sensor, the sensor needs to

be replaced. (The plunger arrival sensor is magnetically activated by the plunger because it is metal. If metal shavings are in the way, the sensor does not sense the metal of the plunger and it remains on, as if detecting the plunger constantly.) Note that the controller will automatically go to Manual Mode in the event of a plunger error.

Q: My Current Status screen indicates “Manual Mode – Sensor Error”...now what?

A: An error message indicates a disconnected or malfunctioning pressure transducer. There are three transducers: Line, Tubing, and Casing. When the top line of the screen indicates “Sensor Error”, the bottom line will show pressures for two of those and “ERR” on the problem transducer. Check the wire at the connection of the appropriate transducer to verify a good connection. If the wires have proper contact, the transducer needs to be replaced. Contact your sales representative. Note that the controller will automatically go to Manual Mode in the event of a sensor error.

Rules Of Thumb

- Start [Load Factor] at 30% and then adjust accordingly.
- Lowest bottom hole flowing pressure is desirable.
- Ideal plunger speed is between 750 and 800 feet per minute.
- Fluid column height (ft.) = $\text{Diff} / 0.07794$
- Fall through dry pipe = 1000 feet per minute
- Fall through gaseous liquid = 250 feet per minute
- Plunger fall time is roughly 5 minutes per 1000 feet
- Ideal plunger arrival time (min.) = $\text{Depth} / 750$

Multi Products Company – Diverse Line of Products

Contact Multi Products for all your Wellhead Efficiency needs:

Automation

- Pressure Controllers
- Time Controllers
- Flow Measurement Systems
- Accessories, including Sensors, Solar Panels, and Alarms



Casing Plunger System

Wellhead Equipment

- Plungers
- Lubricators
- Motor Valves
- Flow Chokes
- Bottom Hole Springs
- Accessories, including Broaches, Retrieval Tools, and Drip Pots



Vapor Recovery System



Pumpjack Control



Field Services



www.plungerlift.com
1-800-777-8617

Limited Warranty

Multi Products Company products are warranted to be free from defects in material and workmanship for a period of ONE (1) YEAR. Parts will be replaced free of charge for the full warranty period, and labor to replace defective parts will be provided at no charge for One Hundred Eighty (180) days from the date of receipt of registration information. Thereafter, purchaser must pay for the labor involved in repairing the product or replacing the parts at the prevailing rate, together with any transportation charges to or from the place where warranty service is provided. This warranty is extended by Multi Products Company, 7188 State Route 39 East, Millersburg, Ohio 44654, to the original purchaser only.

THIS WARRANTY IS GIVEN IN LIEU OF ALL OTHER WARRANTIES, EXPRESS OR IMPLIED, WHICH ARE SPECIFICALLY EXCLUDED, INCLUDING WARRANTIES OF MERCHANTABILITY OR FITNESS FOR A PARTICULAR PURPOSE. IN NO EVENT SHALL MULTI PRODUCTS COMPANY BE LIABLE FOR INCIDENTAL OR CONSEQUENTIAL DAMAGES TO THE FULL EXTENT SUCH MAY BE DISCLAIMED BY LAW.

In the event of a defect, malfunction, or failure to conform to specifications established by seller, or if appropriate, to specifications accepted by seller in writing during the period shown, Multi Products Company, at its option, will either repair or replace the product or refund the purchase price thereof, and such action on the part of Multi Products Company shall be the full extent of Multi Products Company's liability hereunder.

This warranty is void if:

- a) The product is used in other than its normal and customary manner, including corrosive environments.
- b) The product has been subject to misuse, accident, neglect or damage.
- c) Unauthorized alterations or repairs have been made, or unapproved parts used in the equipment.
- d) The registration information has not been submitted to Multi Products Company (electronically via website, or via completion and mailing of perforated registration card to the address above) within 30 days of purchase.

In order to obtain performance of this warranty, purchaser must contact its Multi Products Company sales representative or Multi Products Company at the address above.